



Schematic: SAMA5D3 Xplained

SHEET	SHEET NAME
01	Title & Revision History
02	Block Diagram
03	PIO Assignment
04	Power Supply
05	SAMA5D3x-I & USB
06	SAMA5D3x-II & DDR2
07	SAMA5D3x-II & NAND
08	HSMCI
09	Ethernet_ETH0_10/100/1000
10	Ethernet_ETH1_10/100
11	Connectors

DATE	REVISION	DESCRIPTION
19 Feb 2014	SAMA5D3 Xplained RevA	Official Release

					
A	RevA	Embest	19-Feb-14	XXX	XX-XXX-XX
A	INIT EDIT	PPn	27-Sep-13	XXX	XX-XXX-XX
REV	MODIF.	DES.	DATE	VER.	DATE
SAMA5D3 Xplained		SCALE	1/1	REV.	SHEET
Title & Revision History				A	1/11

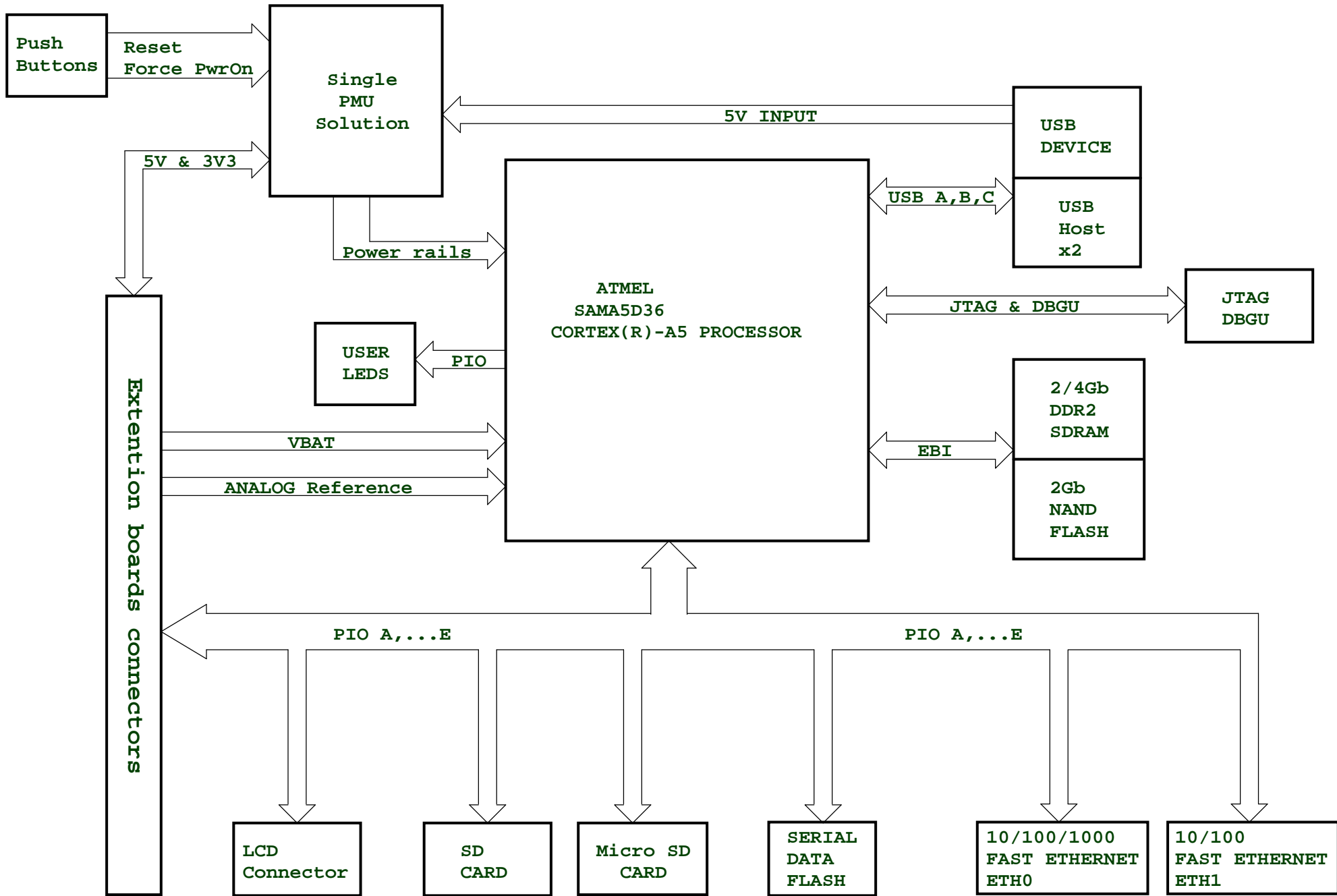

Atmel							
RevA	Embest	19-Feb-14	XXX	XX-XXX-XX			
INIT EDIT	PPn	27-Sep-13	XXX	XX-XXX-XX			
REV	MODIF.	DES.	DATE	VER.	DATE		
SAMA5D3 Explained		SCALE	1/1	REV.	A	SHEET	2/11
Block Diagram							

PIO MUXING

LCD	
ID_SYS	1
GND	2
LCDDAT0	3
LCDDAT1	4
LCDDAT2	5
LCDDAT3	6
GND	7
LCDDAT4	8
LCDDAT5	9
LCDDAT6	10
LCDDAT7	11
GND	12
LCDDAT8	13
LCDDAT9	14
LCDDAT10	15
LCDDAT11	16
GND	17
LCDDAT12	18
LCDDAT13	19
LCDDAT14	20
LCDDAT15	21
GND	22
LCDDAT16	23
LCDDAT17	24
LCDDAT18	25
LCDDAT19	26
GND	27
LCDDAT20	28
LCDDAT21	29
LCDDAT22	30
LCDDAT23	31
GND	32
LCDPCK	33
LCDVSYNC	34
LCDHSYNC	35
LCDDEN	36
SPI0_NPCS3/AD3_YM	37
SPI0_MISO/AD2_YP	38
SPI0_MOSI/AD1_XM	39
SPI0_SPCK/AD0_XP	40
LCDDISP	41
TWD1	42
TWCK1	43
IRQ1	44
IRQ2	45
LCDPWM	46
Reset	47
VCC	48
VCC	49
GND	50

PIOA	USAGE	PIOA	USAGE	PIOB	USAGE	PIOB	USAGE	PIOC	USAGE	PIOC	USAGE
PA0	LCDDAT0	PA16	ISI_D0	PB0	GTX0	PB16	GMDC	PC0	ETX0	PC16	TK0
PA1	LCDDAT1	PA17	ISI_D1	PB1	GTX1	PB17	GMDIO	PC1	ETX1	PC17	TF0
PA2	LCDDAT2	PA18	ISI_D2	PB2	GTX2	PB18	G125CK	PC2	ERX0	PC18	TD0
PA3	LCDDAT3	PA19	ISI_D3	PB3	GTX3	PB19	MCI1_CDA	PC3	ERX1	PC19	RK0
PA4	LCDDAT4	PA20	ISI_D4	PB4	GRX0	PB20	MCI1_DA0	PC4	ETXEN	PC20	RF0
PA5	LCDDAT5	PA21	ISI_D5	PB5	GRX1	PB21	MCI1_DA1	PC5	ECRSVDV	PC21	RD0
PA6	LCDDAT6	PA22	ISI_D6	PB6	GRX2	PB22	MCI1_DA2	PC6	ECRSVDV	PC22	SPI1_MISO
PA7	LCDDAT7	PA23	ISI_D7	PB7	GRX3	PB23	MCI1_DA3	PC7	EREFCK	PC23	SPI1_MOSI
PA8	LCDDAT8	PA24	LCDPWM	PB8	GTXCK	PB24	MCI1_CK	PC8	EMDC	PC24	SPI1_SPCK
PA9	LCDDAT9	PA25	LCDDISP	PB9	GTXEN	PB25	SCK1	PC9	EMDIO	PC25	SPI1_NPCS0
PA10	LCDDAT10	PA26	LCDVSYNC	PB10	INT_GETH	PB26	CTS1	PC10	LCDDAT20	PC26	SPI1_NPCS1/TWD1/ISI_D11
PA11	LCDDAT11	PA27	LCDHSYNC	PB11	GRXCK	PB27	RTS1	PC11	LCDDAT19	PC27	SPI1_NPCS2/TWCK1/ISI_D10
PA12	LCDDAT12	PA28	LCDPCK	PB12	INT_ETH	PB28	RXD1	PC12	LCDDAT18	PC28	SPI1_NPCS3/ISI_D9
PA13	LCDDAT13	PA29	LCDDEN	PB13	GRXER	PB29	TXD1	PC13	LCDDAT17	PC29	URXD0/ISI_D8
PA14	LCDDAT14	PA30	ISI_VSYNC/URXD1	PB14	CANRX1	PB30	DRXD	PC14	LCDDAT16	PC30	UTXD0/ISI_PCK
PA15	LCDDAT15	PA31	ISI_HSYNC/UTXD1	PB15	CANTX1	PB31	DTXD	PC15	LCDDAT21/PCK2	PC31	IRQ_PMIC

PIOD	USAGE	PIOD	USAGE	PIOE	USAGE	PIOE	USAGE
PD0	MCI0_CDA	PD16	SPI0_NPCS3	PE0	MCI0_CD	PE16	A16/CTS3
PD1	MCI0_DA0	PD17	RXD0	PE1	MCI1_CD	PE17	A17/RTS3
PD2	MCI0_DA1	PD18	TXD0	PE2	PWR_MCI0	PE18	A18/RXD3
PD3	MCI0_DA2	PD19	ADTRG	PE3	EN5V_USBB	PE19	A19/TXD3
PD4	MCI0_DA3	PD20	AD0	PE4	EN5V_USBC	PE20	A20/SCK2
PD5	MCI0_DA4	PD21	AD1	PE5	OVCUR_USB	PE21	A21/NANDALE
PD6	MCI0_DA5	PD22	AD2	PE6	RST_LCD	PE22	A22/NANDCLE
PD7	MCI0_DA6	PD23	AD3	PE7	IRQ1	PE23	1-Wire/User led1/A23/CTS2
PD8	MCI0_DA7	PD24	AD4	PE8	IRQ2	PE24	Power led/A24/RTS2
PD9	MCI0_CK	PD25	AD5	PE9	VBUS_SENSE/A9	PE25	A25/RXD2
PD10	SPI0_MISO	PD26	AD6	PE10	A10	PE26	NCS0/TXD2
PD11	SPI0_MOSI	PD27	AD7	PE11	A11	PE27	LCDDAT22
PD12	SPI0_SPCK	PD28	AD8	PE12	A12	PE28	LCDDAT23
PD13	SPI0_NPCS0	PD29	AD9	PE13	A13	PE29	NWR1/NBS1/TCLK2
PD14	SCK0/CANRX0	PD30	AD10/PCK0	PE14	A14	PE30	STA_PMIC
PD15	CTS0/CANTX0	PD31	/PCK1	PE15	A15/SCK3	PE31	ADTRG/PWML1

JUMPER DESCRIPTION		
PART	DEFAULT	FUNCTION
JP1	SHORT	I_CORE Measurement
JP2	SHORT	I_ODDR Measurement
JP3	SHORT	I_IOP Measurement
JP4	SHORT	I_IOM Measurement
JP5	CLOSE	CS Nand flash memory
JP6	CLOSE	CS Serial flash memory

RevA	Embest	19-Feb-14	XXX	XX-XXX-XX					
INIT EDIT	PPn	27-Sep-13	XXX	XX-XXX-XX					
REV	MODIF.	DES.	DATE	VER.	DATE				
SAMA5D3 Explained		SCALE	1/1	REV.	A	SHEET		3/11	
PIO Assignment									

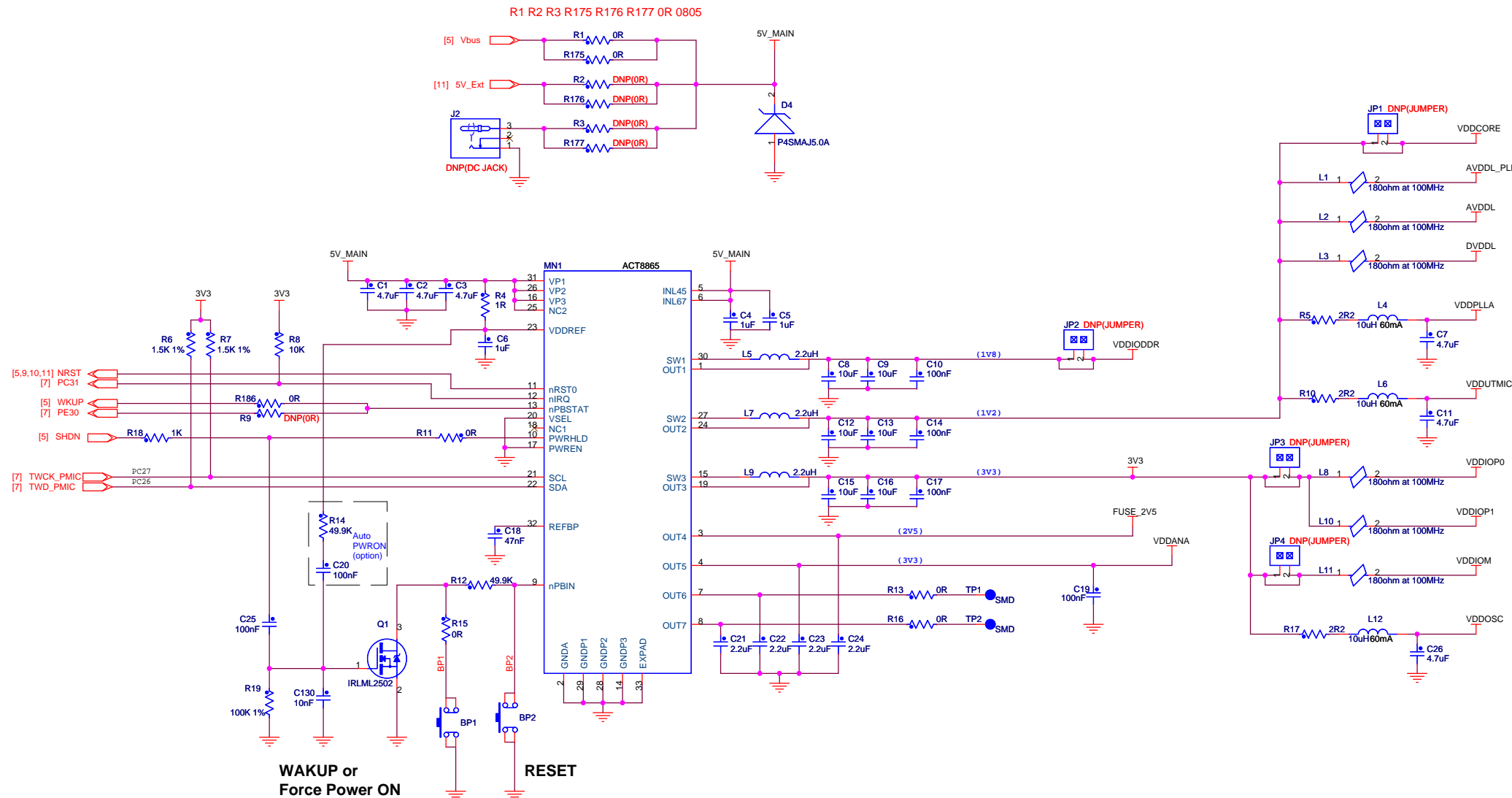

- [5,9,10,11] NRST PC31
- [7] WKUP PE30
- [5] SHDN PC27
- [7] TWCK_PMIC PC26
- [7] TWD_PMIC PC26

WAKUP or Force Power ON

RESET

SMD TP6 ● BP1
 SMD TP7 ● BP2
 Place TP6 TP7 to Bottom

Atmel		RevA	Embtest	19-Feb-14	XXX	XX-XXX-XX
		INIT EDIT	PPn	27-Sep-13	XXX	XX-XXX-XX
SAMA5D3 Explained		SCALE	1/1	REV.	SHEET	
Power Supply		REV. A		SHEET 4/11		

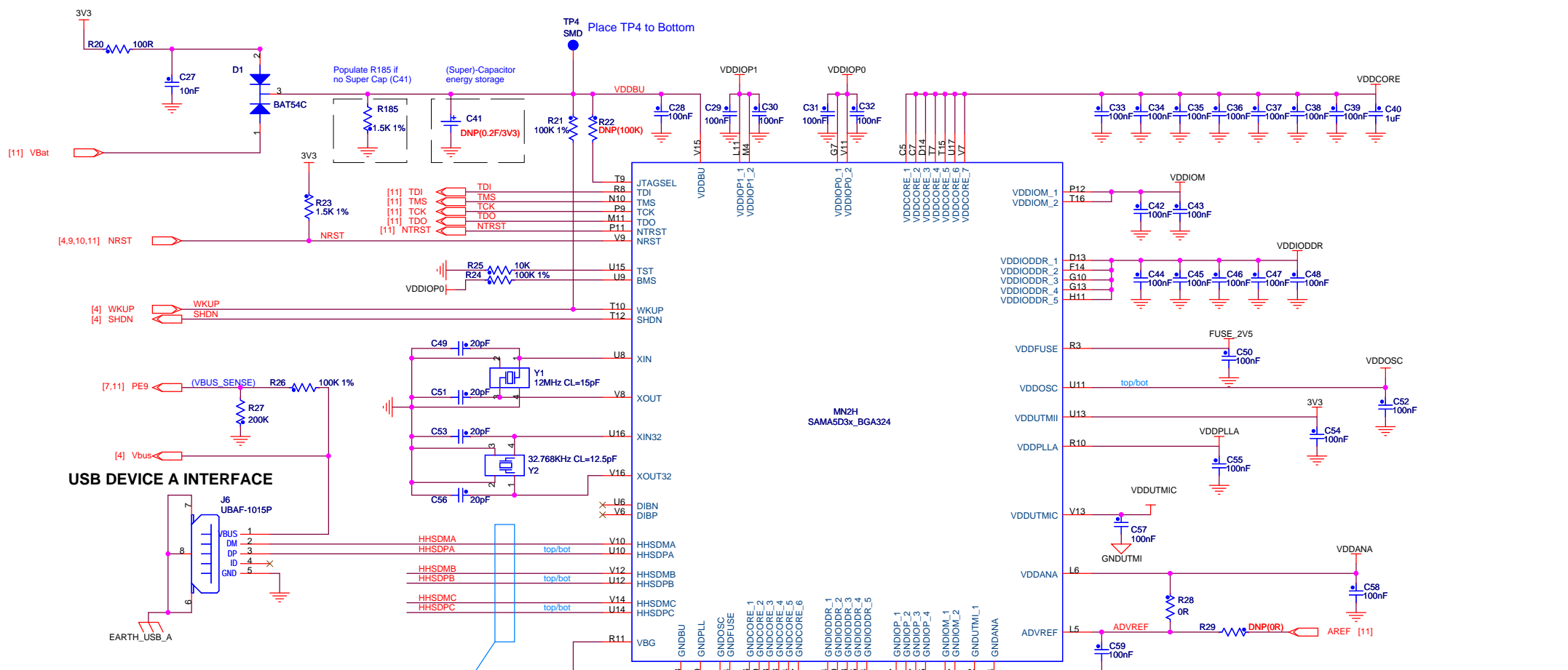

USB DEVICE A INTERFACE

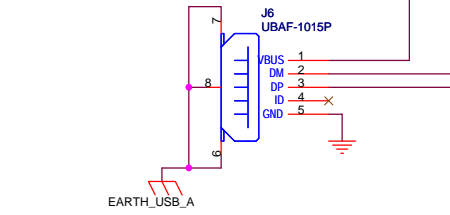

Routing USB

Max trace-length mismatch between USB signals pairs should be no greater than 3.8mm
 90 ohms differential trace impedance
 Routing top or bottom

A copper plan for GNDUTMI cover all USB components

J7_USB_A_Up USB8S-AR2HF-NBW-S2 J7_USB_B_Down

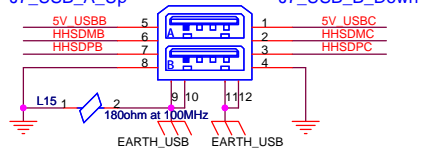

USB HOST B&C INTERFACE

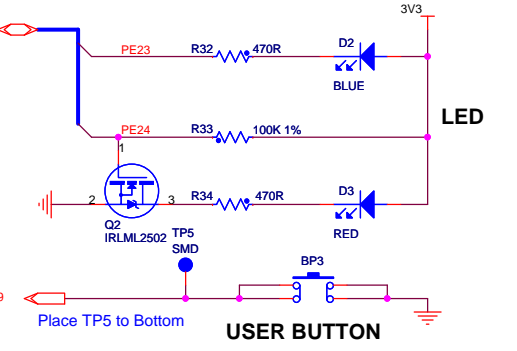
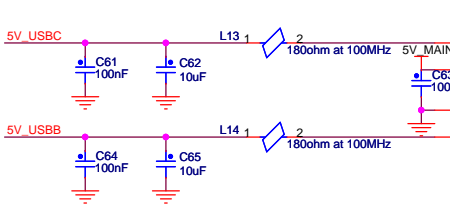

Atmel							
RevA	Embtest	19-Feb-14	XXX	XX-XXX-XX			
INIT EDIT	PPn	27-Sep-13	XXX	XX-XXX-XX			
REVI	MODIF.	DES.	DATE	VER.	DATE		
SAMA5D3 Explained		SCALE 1/1		REV. A		SHEET 5/11	
SAMA5D3x-1 & USB							

MN2F
SAMA5D3x_BGA324

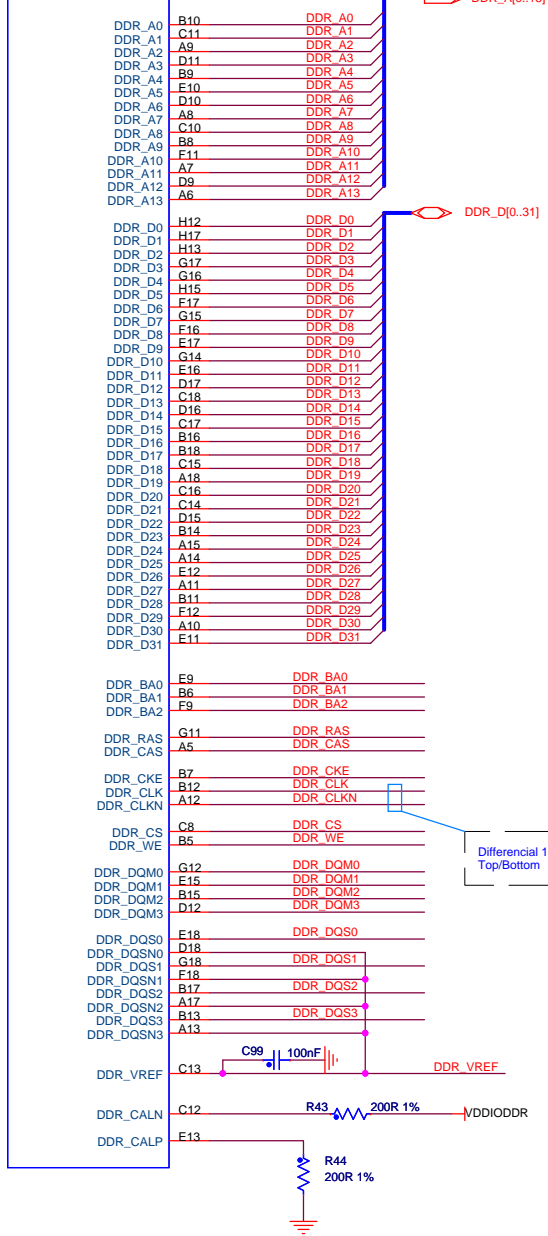

DDR2 SDRAM

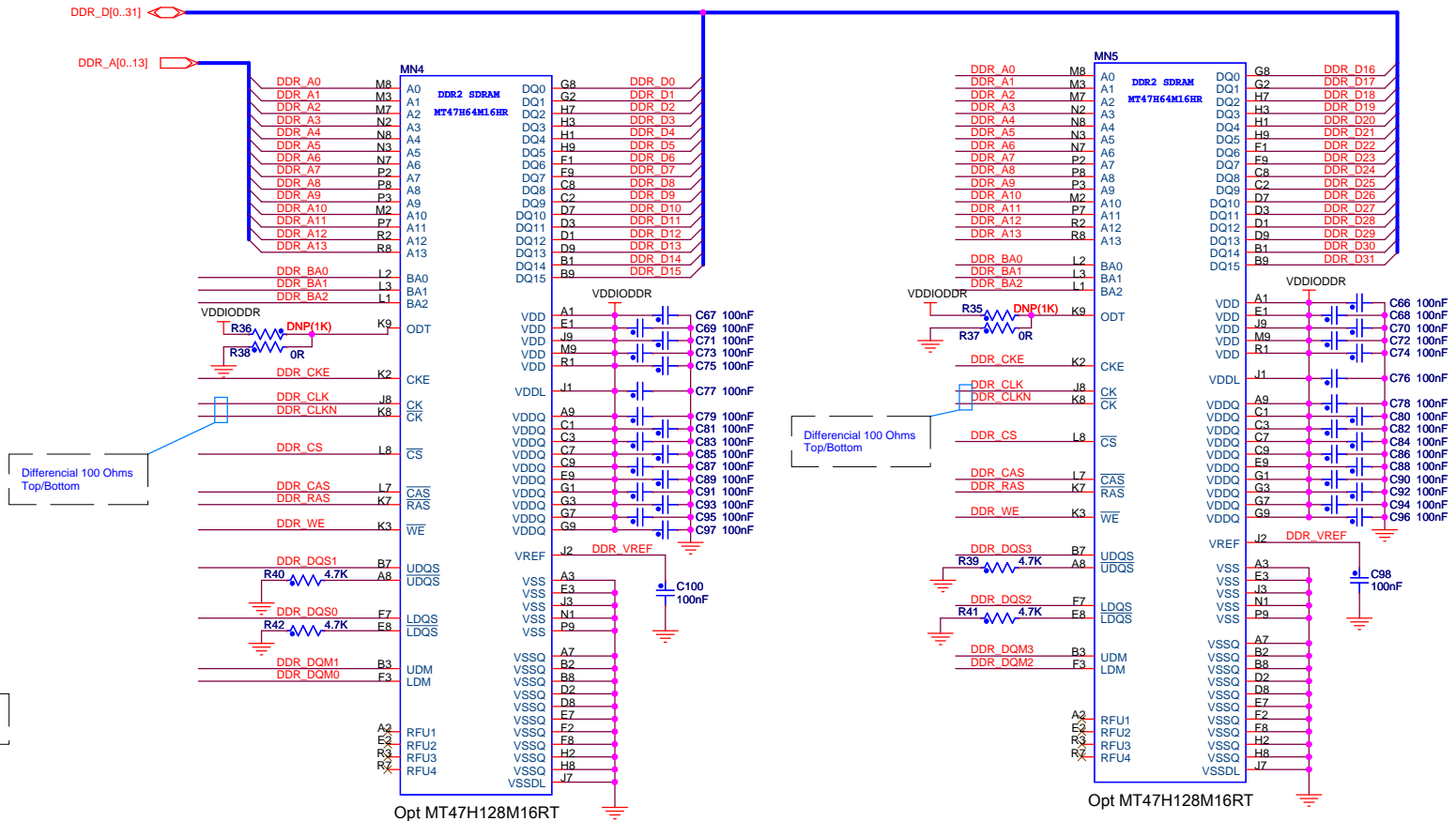

Keep nets as short as possible, therefore, DDR2 devices have to be placed close as possible of SAMA5D36
 The layout EBI DDR2 should use controlled impedance traces of ZO= 50ohm characteristic impedance.
 Address, control and data traces may not exceed 1.3 inches (33.0 mm).
 Address, control and data traces must be length-matched to within 0.1 inch (2.54mm).
 Address, control and data traces must match the data group trace lengths to within 0.25 inches (6.35mm).

		RevA		Embest 19-Feb-14		XXX XX-XXX-XX	
		A INIT EDIT		PPn 27-Sep-13		XXX XX-XXX-XX	
SAMA5D3 Explained		SCALE 1/1		REV. DATE		A SHEET 6/11	
SAMA5D3x-II & DDR2							

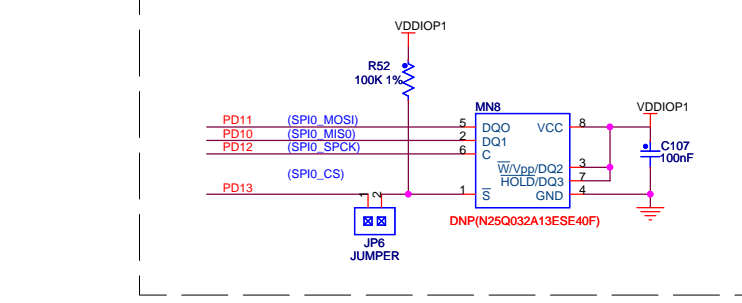
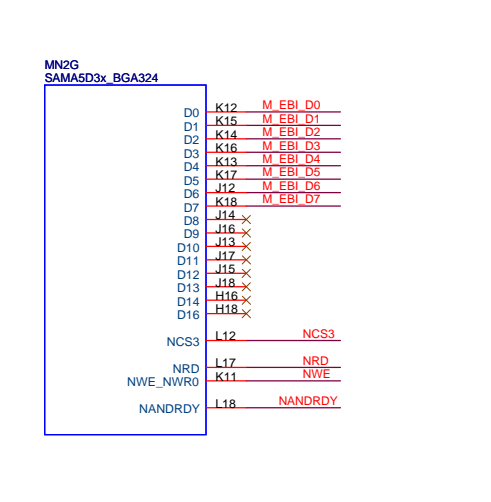
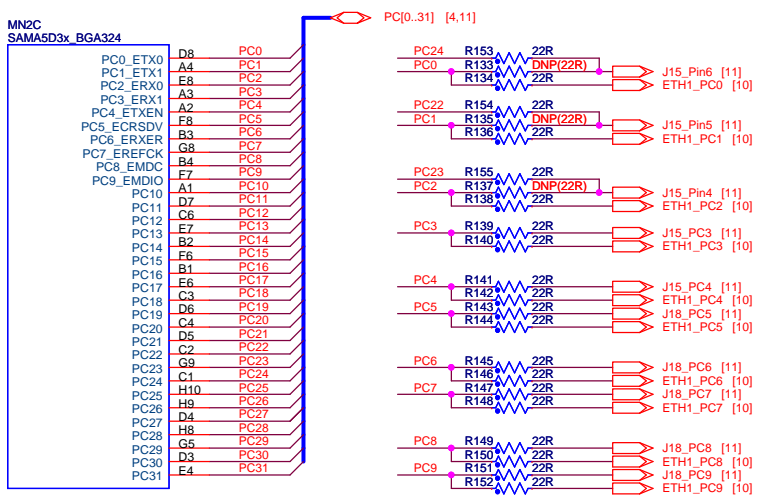
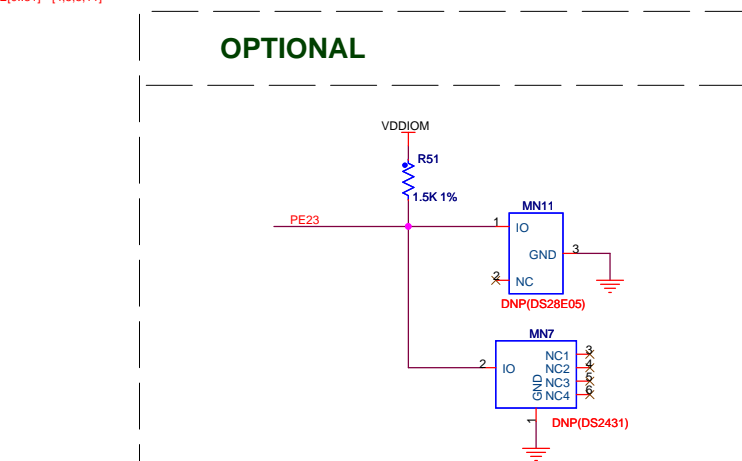
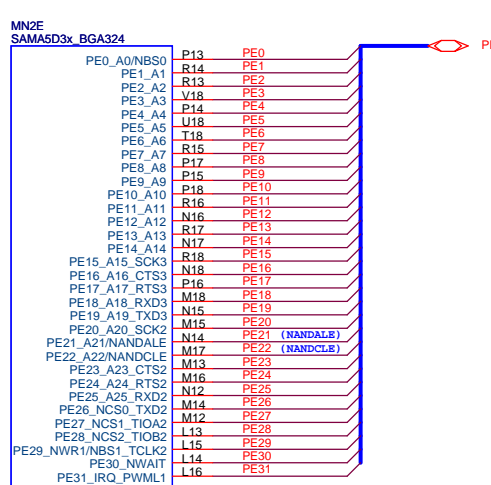
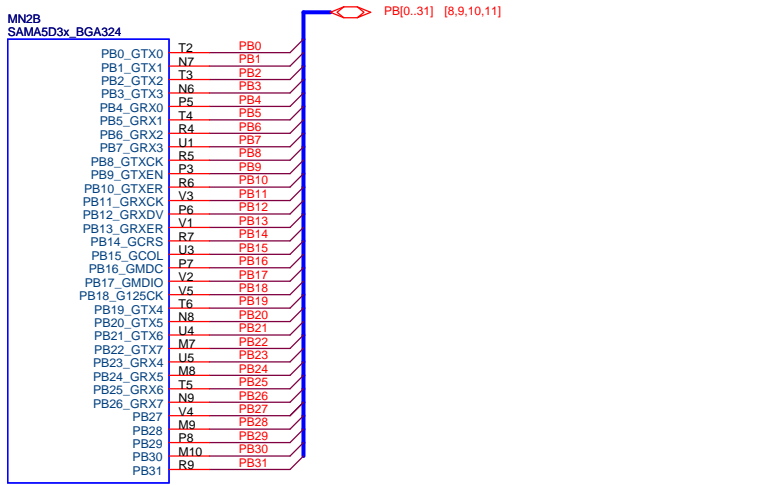
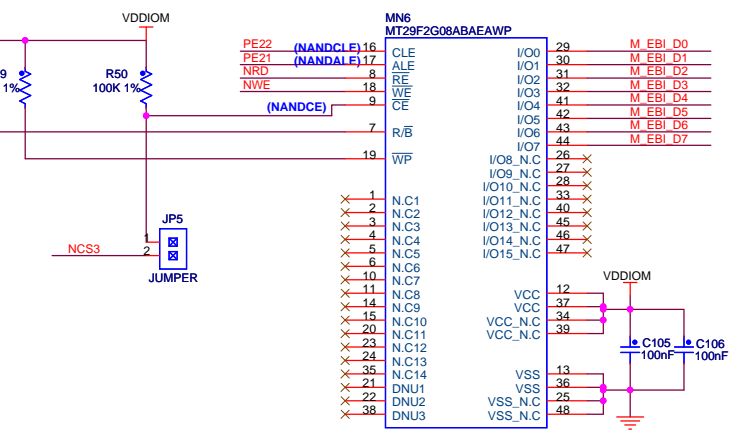
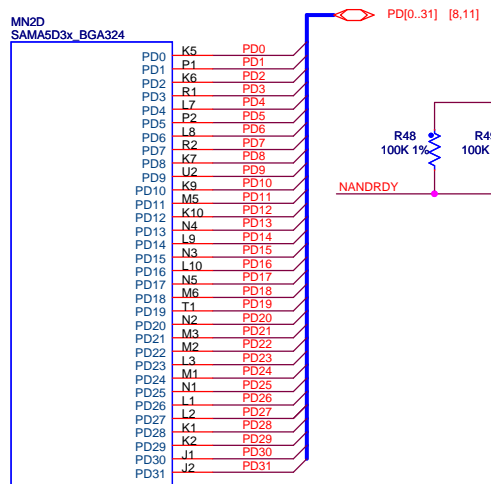
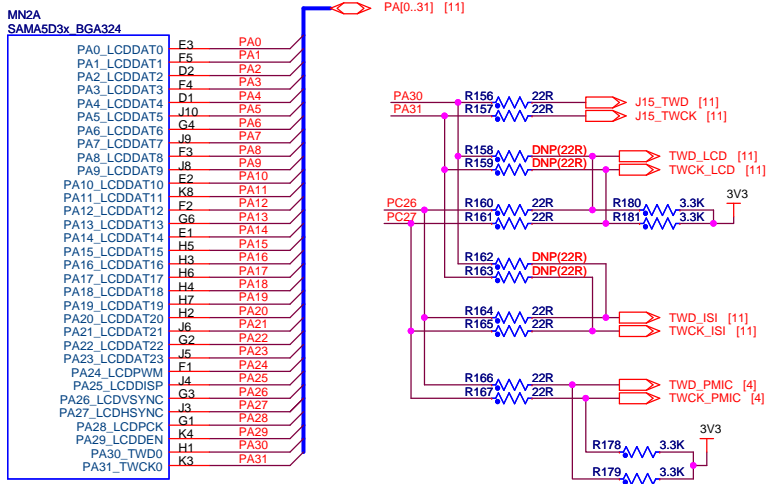

Atmel									
RevA	Embset	19-Feb-14	XXX	XX-XX-XX					
INIT EDIT	PPn	27-Sep-13	XXX	XX-XX-XX					
MODIF.	DES.	DATE	VER.	DATE					
SCALE 1/1				REV. A		SHEET 7/11			
SAMA5D3 Explained									
SAMA5D3x-II & NAND									

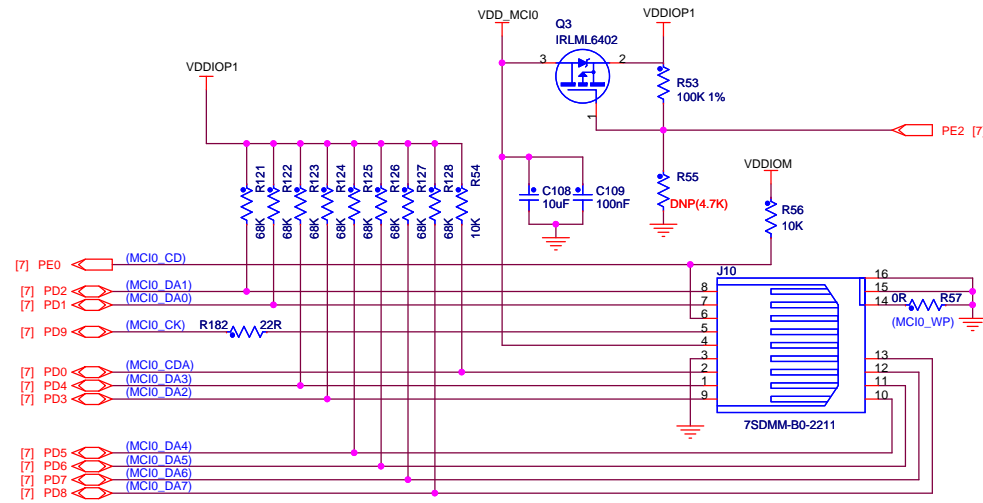

SD/MMCPlus CARD INTERFACE - MCI0

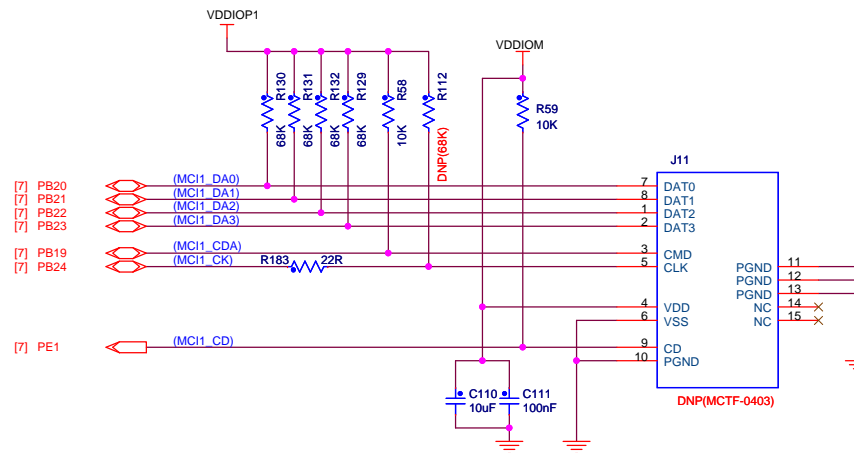

Micro SD CARD INTERFACE - MCI1

		RevA		Embest 19-Feb-14		XXX XX-XXX-XX	
		A INIT EDIT		PPn 27-Sep-13		XXX XX-XXX-XX	
SAMA5D3 Xplained		SCALE 1/1		REV. A		SHEET 8/11	
HSMCI							

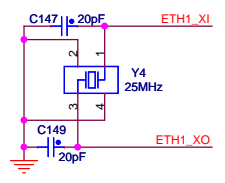
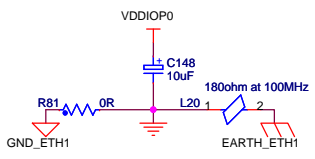
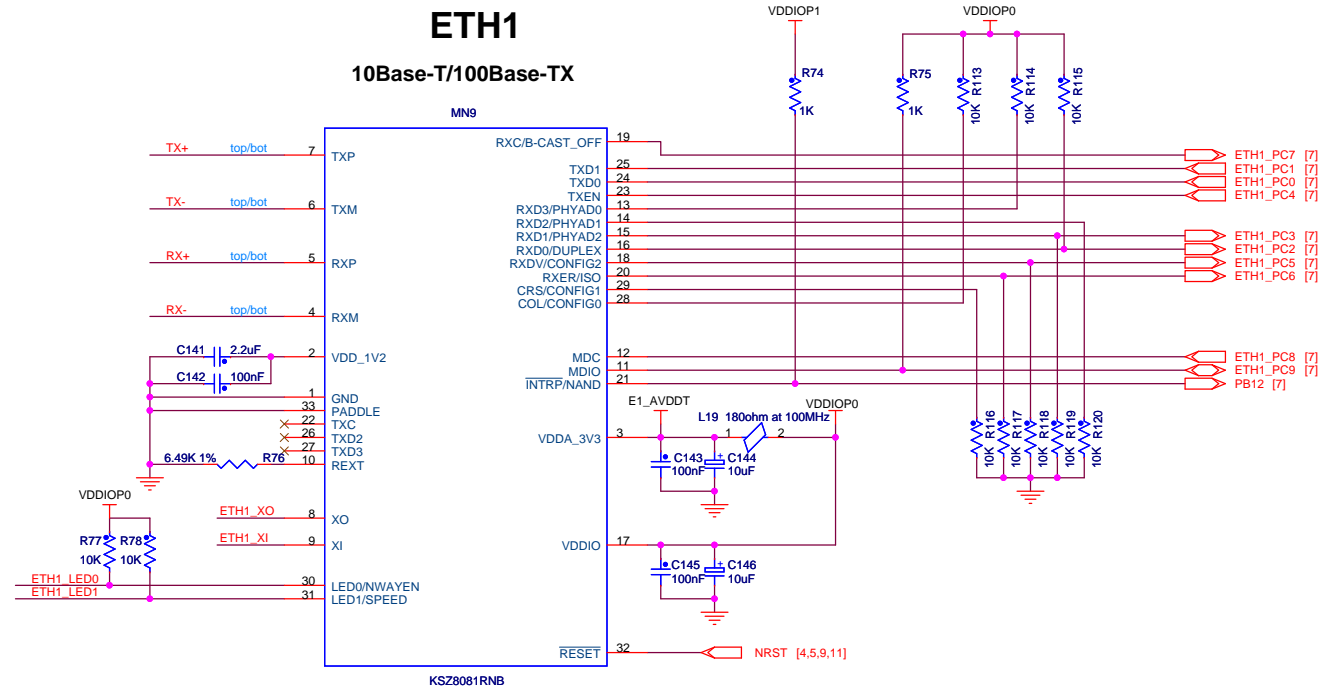
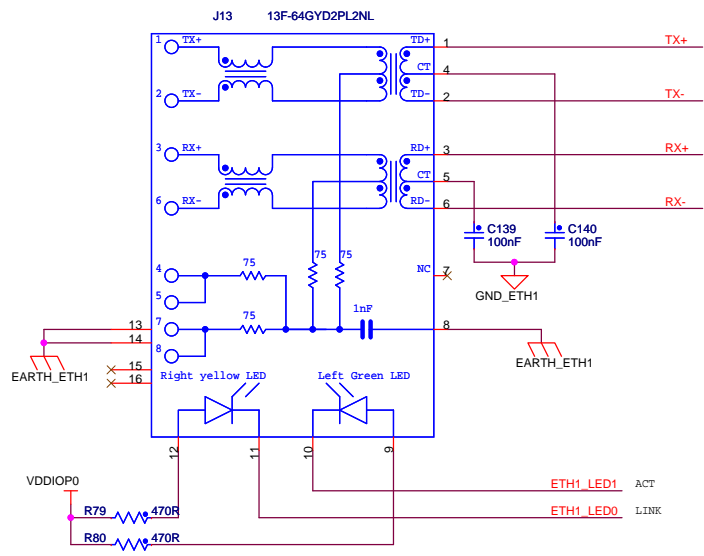

Atmel					
RevA	Embest	19-Feb-14	XXX	XX-XXX-XX	
INIT EDIT	PPn	27-Sep-13	XXX	XX-XXX-XX	
REV1	MODIF.	DES.	DATE	VER.	DATE
SAMA5D3 Xplained			SCALE 1/1	REV. A	SHEET 10/11
Ethernet_ETH1_10/100					

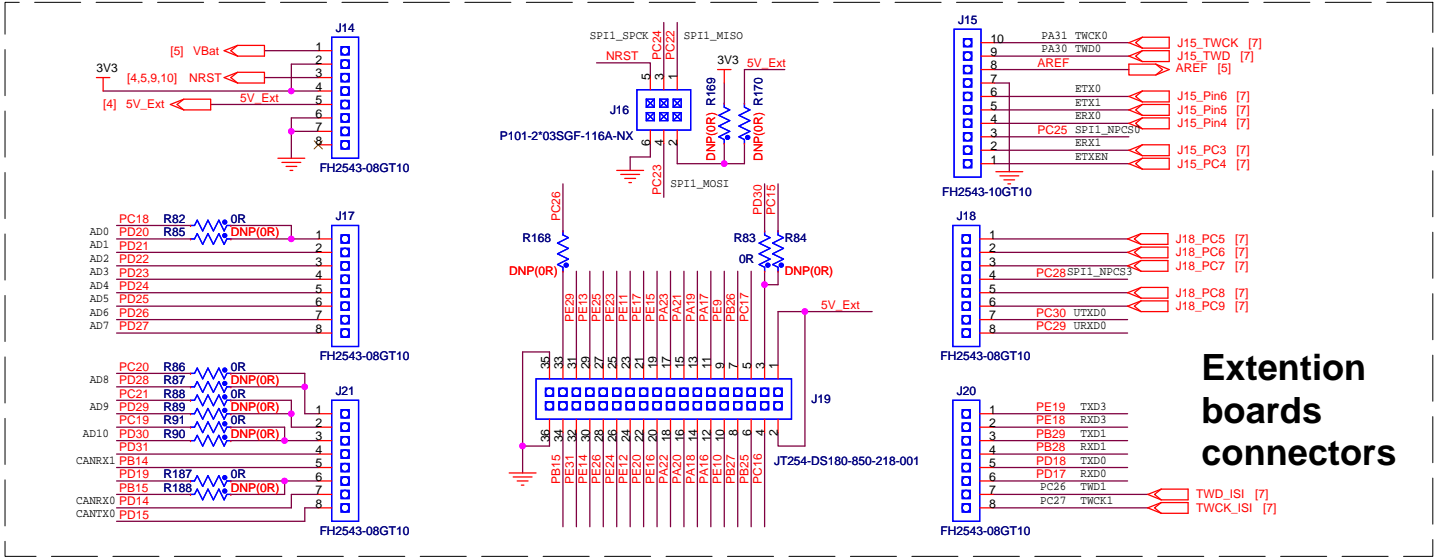
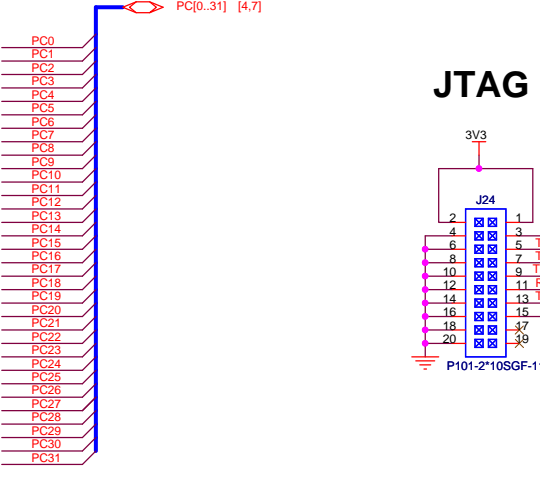
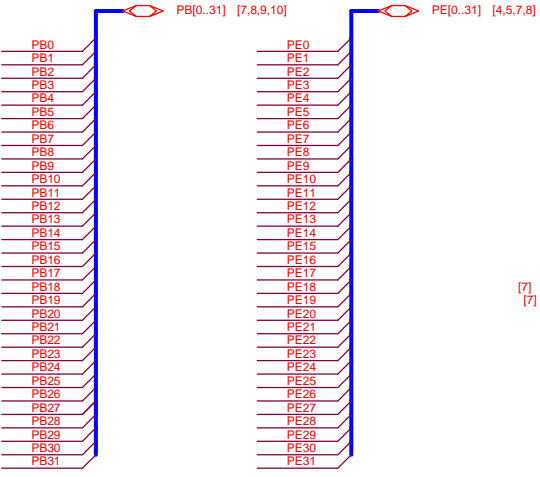
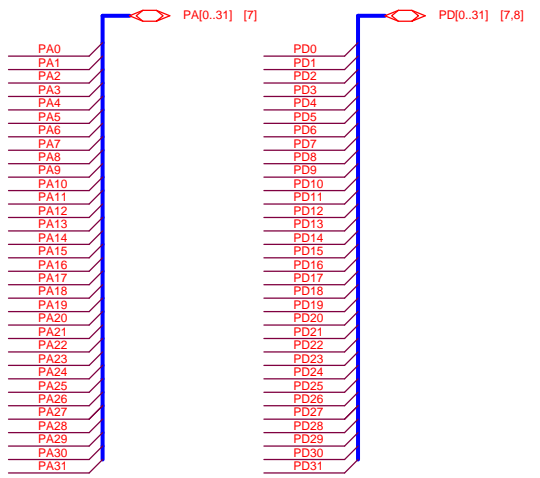

Extention boards connectors

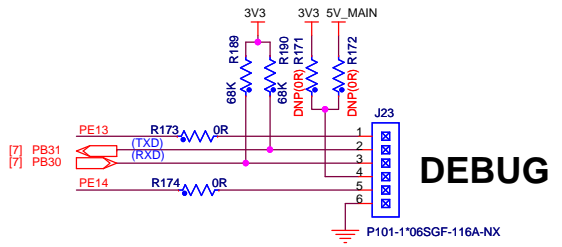
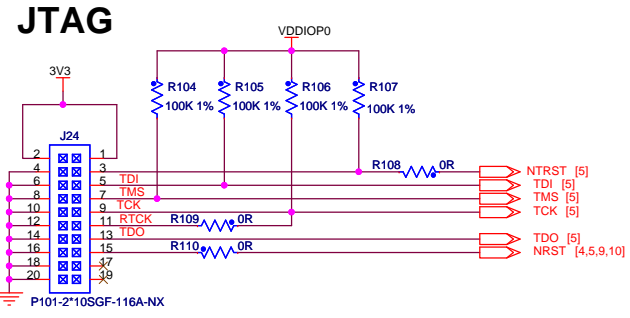
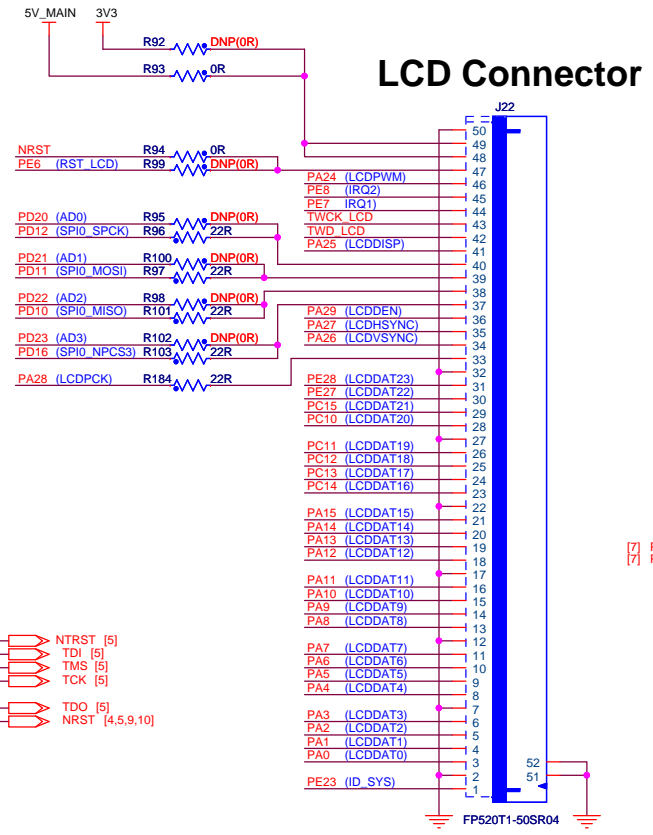

Atmel		SAMA5D3 Explained		Connectors	
RevA	Embest	19-Feb-14	XXX	XX-XXX-XX	
INIT EDIT	PPn	27-Sep-13	XXX	XX-XXX-XX	
REVI	MODIF.	DES.	DATE	VER.	DATE
SCALE	1/1			REV.	SHEET
				A	1/11